

ATHOLE: Low power consumption for embedded systems

Background

The increasing complexity of applications requires ever more powerful calculation performance (such as for video streaming to mobile telephones, for instance). However, users demand longer and longer battery life.

Partners

Corporate

STMicroelectronics (Grenoble/Crolles)
Thales Communication (Colombes)

SME

CWS (Coupling Wave Solutions)

Research laboratories

CEA Leti - Verimag

Key figures

Budget: €10.2 million

Duration: 3 years

Human resources allocated: 72 people per year



Innovation

Study and develop a new, flexible and programmable architecture for embedded systems that will meet the following criteria:

- Excellent performance,
- Low power-consumption,
- Multiprocessor or Network-on-Chip (NoC) architecture.

The innovation lies in estimating and optimizing software and hardware electrical consumption far in advance of the design flow for multiprocessor or NoC-type architectures, with task organization and management, the study and development of dedicated operators (silicon), and dynamic activity management, for instance.

xStream architecture

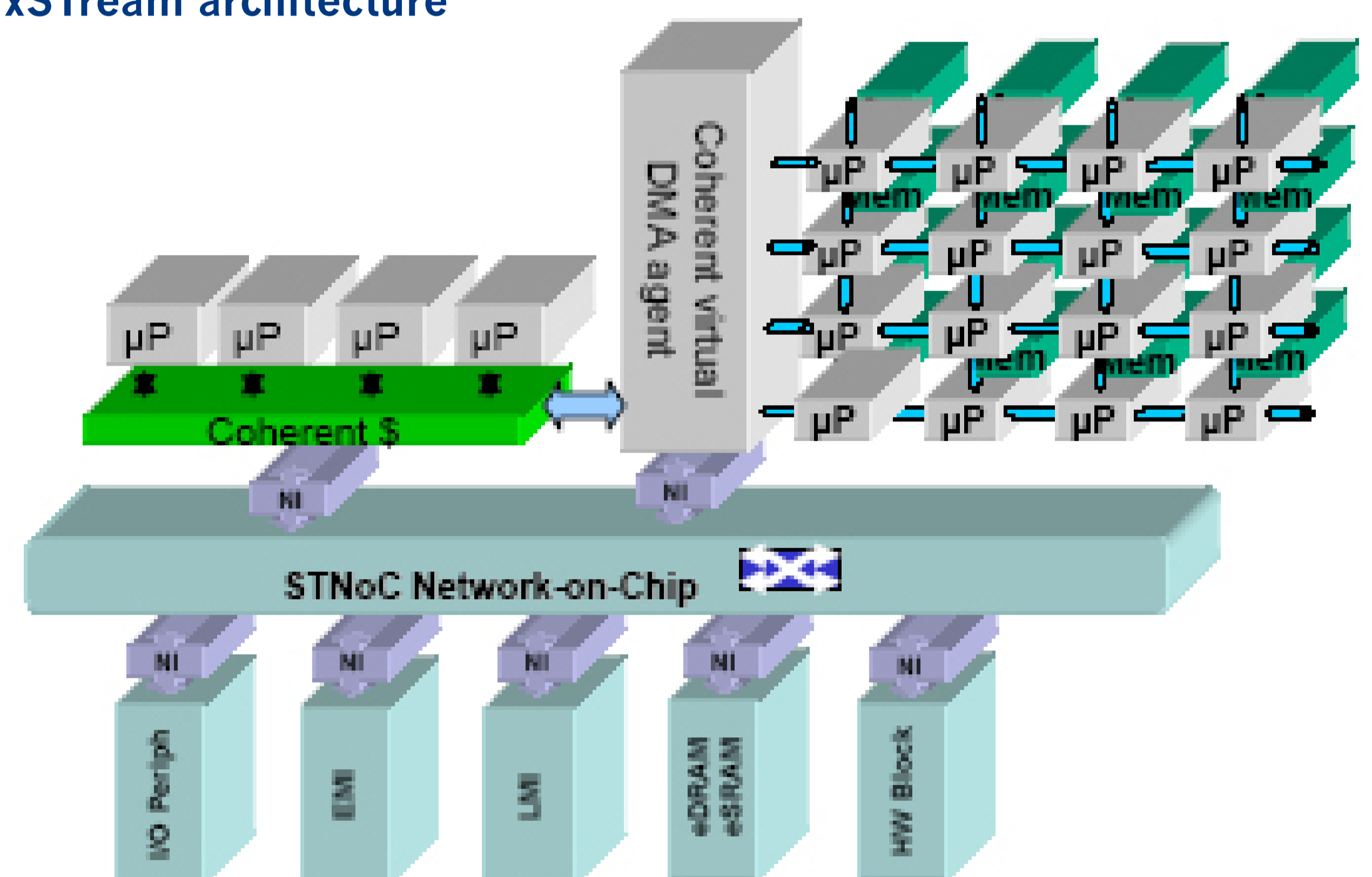

FAUST/SDR component

